

Dimensions

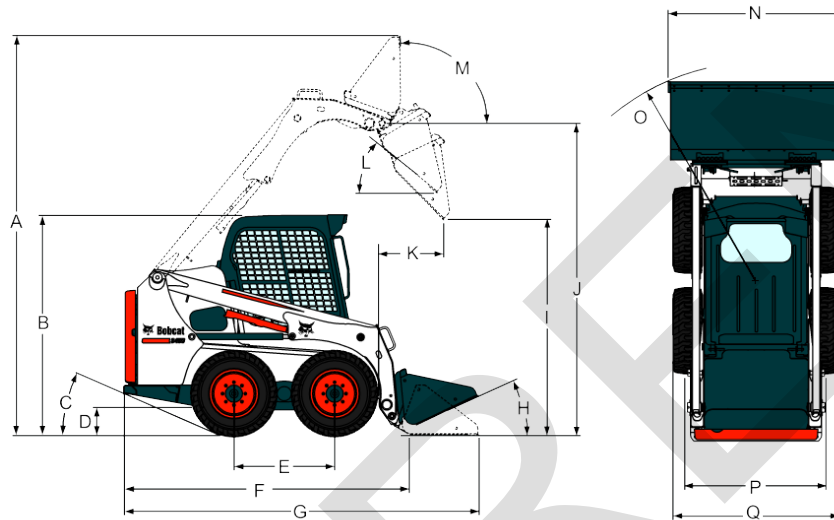

(A) Operating height	3558.0 mm
(B) Height with operator cab	1976.0 mm
(C) Angle of departure	23°
(D) Ground clearance	214.0 mm
(E) Wheelbase	900.0 mm
(F) Length without attachment	2502.0 mm
(G) Length with standard bucket	3172.0 mm
(H) Rollback at ground position	26°
(I) Dump height with standard bucket	2157.0 mm
(J) Height to bucket hinge pin	2781.0 mm
(K) Dump reach at maximum height	587.0 mm
(L) Dump angle at maximum height	40°
(M) Rollback fully raised at maximum height	96°
(N) Width over standard bucket	1575.0 mm
(O) Turning radius with standard bucket	1940.6 mm
(P) Track, standard tyres	1221.7 mm
(Q) Width over standard tyres	1490.0 mm
(Q) Width over tyres, 10 x 16.5, 10-ply, Heavy duty, offset rims	1355.0 mm
(Q) Width over tyres, 31 x 12-16.5, 10-ply, Superflotation	1670.0 mm

Machine Rating

Lift breakout force	1180 daN
Tilt breakout force	1200 daN
Rated operating capacity (ISO 14397-1)	608 kg
Tipping load	1215 kg
Axle torque	4868.0 Nm

Cycle Times

Raise lift arms	3.2 s
Lower lift arms	2.5 s
Bucket rollback	1.4 s
Bucket dump	1.8 s

Weights

Operating weight	2240 kg
Shipping weight	2052 kg

Engine

Make / Model	Kubota / V2203-M-DI-E2B-BC-3
Fuel	Diesel
Cooling	Liquid
Power at 2400 RPM	36.4 kW
Rated speed (EEC 80/1269, ISO 9249)	3000.0 RPM
Torque at 1425 RPM (SAE J1 995 Gross)	150.0 Nm
Number of cylinders	4
Displacement	2196 cm ³
Bore	87.0 mm
Stroke	92.4 mm
Lubrication	Pressure system with filter
Crankcase ventilation	Closed
Air filter	Dry replaceable cartridge with safety element
Ignition	Diesel-compression
Starting aid	Glow plugs

Electrical

Alternator	90 A
Battery	12 V — 600 cold cranking A at -18°C — 115 min reserve capacity at 25 A
Starter	12 V — gear type — 3.0 kW

Hydraulic System

Pump type	Engine driven, gear type
Pump capacity	64.00 L/min
System relief at quick couplers	22.4-23.1 MPa
Control valve	Three-spool, open-centre type with float detent on lift and electrically controlled auxiliary spool
Hydraulic filter	Full-flow replaceable, in tank
Fluid lines	SAE standard tubelines, hoses, and fittings

Hydraulic Cylinders

Lift cylinder (2)	Double-acting
Lift cylinder bore	50.8 mm
Lift cylinder rod	31.8 mm
Lift cylinder stroke	665.0 mm
Tilt cylinder (2)	Double-acting with cushioning feature on dump and rollback
Tilt cylinder bore	60.5 mm
Tilt cylinder rod	31.8 mm
Tilt cylinder stroke	357.0 mm

Drive System

Transmission	Infinitely variable tandem hydrostatic piston pumps, driving two fully reversing hydrostatic motors
Final drive chains	Pre-stressed #80 HSOC endless roller chain (no master link) and sprockets in sealed chaincase with oil lubrication. (Chains do not require periodic adjustments.) Two chains per side with no idler sprocket.
Main drive	Fully hydrostatic; four-wheel drive
Axle size	50.8 mm, heat treated. Axle tubes welded to chaincase. Labyrinth axle seal protection.
Wheel bolts	Eight 9/16-inch wheel bolts fixed to axle hubs

Traction

Standard tyres	10 x 16.5, 10-ply, Bobcat heavy duty
Severe duty tyres	10 x 16.5, 10-ply, Bobcat severe duty
Poly fill tyres	10 x 16.5, 10-ply, Bobcat severe duty, poly filled
Solid flex tyres (option)	10 x 16.5, Solid Flex tyres
Max. travel speed (low range)	11.4 km/h
Max. travel speed (high range - option)	14.8 km/h

Fluid Capacities

Chaincase reservoir	21.00 L
Cooling system	9.50 L
Engine oil with filter	8.70 L
Fuel tank	54.50 L
Hydraulic reservoir	5.30 L
Hydraulic / Hydrostatic system	36.00 L

Fluid Specifications

Engine coolant

Propylene glycol/water mix (53% - 47%) with freeze protection to -37°C

5 L can - 6904844A, 25 L container - 6904844B, 209 L drum - 6904844C, 1000 L tank - 6904844D

Engine oil

Oil must meet API Service Classification of CD, CE, CF4, CG4, or better. Recommended SAE viscosity number for anticipated temperature range.

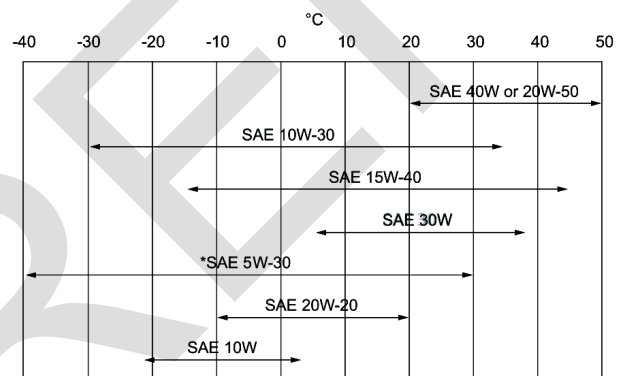

Hydraulic fluid

* Can be used only when available with appropriate diesel rating. For synthetic oil use the recommendation from the oil manufacturer.

Bobcat Superior SH, 5 L can - 6904842A, 25 L container - 6904842B, 209 L drum - 6904842C, 1000 L tank - 6904842D

Bobcat Bio Hydraulic, 5 L can - 6904843A, 25 L container - 6904843B, 209 L drum - 6904843C, 1000 L tank - 6904843D

Motor oil is not an acceptable alternative fluid.

Controls

Engine Starting

Hand lever throttle

Key-type starter switch and shutdown or optional keyless start. Glow plugs automatically activated by Standard or Deluxe instrument panel.

Front auxiliary (standard) Rear auxiliary (optional) Loader hydraulics tilt and lift

Electrical switch on right-hand steering lever

Electrical switch on left-hand steering lever

Service brake

Separate foot pedals or optional Advanced Control System (ACS) or Selectable Joystick Controls (SJC)

Two independent hydrostatic systems controlled by two hand-operated steering levers

Secondary brake Parking brake

One of the hydrostatic transmissions

Mechanical disc, hand-operated rocker switch on dash panel

Vehicle steering Auxiliary pressure release

Direction and speed controlled by two hand levers

Pressure is relieved through the coupler block. Push in and hold for 5 s.

Instrumentation

The following loader functions are monitored by a combination of gauges and warning lights in the operator's line of sight. The system alerts the operator of monitored loader malfunctions by way of audible alarm and visual warning lights.

Standard Instrument Panel

- Gauges
 - Engine coolant temperature
 - Fuel
- Indicators
 - Bobcat Interlock Control System
 - Engine preheat
 - Two speed
 - Turn signals
- Warning lights
 - Engine coolant temperature
 - Fuel level
 - General warning
 - Seat belt
 - Seatbar down
 - Engine malfunction
 - Hydraulic system malfunction
 - Lift and tilt valve, hydraulics lock-out
 - Parking brake
 - Hydraulic oil temperature
 - Engine oil pressure
 - Hydraulic oil pressure
- Buttons
 - Work lights and road lights
 - High flow auxiliary hydraulics
 - Auxiliary hydraulics
 - Information (Hour meter, Engine RPM, Battery voltage, Service codes, Service reminder, Maintenance clock)
 - Traction lock override
 - Press to operate loader
- Rocker switch
 - Parking brake
- Alarm
 - Beep when error, warning or shutdown condition exists

Deluxe Instrument Panel (Option)

Same gauges, warning lights and other features as Standard Instrument Panel, plus:

- Gauges
 - Engine oil pressure / temperature
 - Hydrostatic charge pressure
 - Hydraulic oil temperature
 - Battery

- Additional features
 - Keyless start with password capability
 - Digital clock
 - User name and hourmeter
 - Attachments control information
 - Current job hours
 - High Flow lockouts
 - Multi-language display
 - Help screens
 - Diagnostic capability
 - Engine/hydraulic systems shutdown function
 - Password lockout
- Icons
 - Active warnings
 - Vitals (Engine speed, Oil Pressure, Temperature, System voltage, Hydraulic charge pressure, Oil temperature)
 - Service
 - Main screen
 - Attachments
 - Security
 - Display
- Buttons
 - Left scroll
 - Enter
 - Right scroll

Serviceability

Access is available to the following through the rear door/tailgate and rear screen:

- Air cleaner
- Alternator
- Battery
- Cooling system (engine oil and hydraulic oil coolers easily separable) for cleaning
- Engine oil and fuel filters
- Engine oil drain and dipstick
- Hydraulic oil fill (access at the side of the machine)
- Starter

Axle hubs provide protection for the axle seals

Bob-Tach™ pivots have replaceable wear bushings

Easy access to all lift arm grease points

Rod end of the tilt cylinder has a replaceable bushing

Tailgate has an optional lock for vandal-proofing

Tailgate is equipped with door-stop to hold door open while servicing

Tip-up operator cab gives access to certain hydraulic system components

Standard Features

- Cushion suspension seat
- Automatically activated glow plugs
- Auxiliary hydraulics: variable flow/maximum flow
- Bob-Tach™ frame
- Bobcat Interlock Control System (BICS)
- 10 x 16.5, 10-ply, Heavy duty tyres
- Deluxe operator cab* Includes interior cab foam, side, top and rear windows, Deluxe wire harness, dome light, and electrical power port ¹

- Electrically activated proportional front auxiliary hydraulics
- Engine/hydraulics system shutdown
- Instrumentation
- Lift arm support
- Noise reduction kit
- Operating lights, front and rear
- Parking brake
- Seat belt
- Seat bar
- Spark arrestor muffler
- CE certification
- Warranty: 12 months or 2000 hours (whichever occurs first)

Options

- Factory Options
 - Deluxe instrument panel
 - Power Bob-Tach™
 - Cab enclosure
 - Cab enclosure with heating
 - Cab enclosure with HVAC
 - Hydraulic bucket positioning (including ON/OFF switch)
 - 10 x 16.5, 10-ply, Severe duty tyres
 - 10 x 16.5, 12-ply, Severe duty tyres, poly filled
 - 10 x 16.5, Solid Flex tyres
 - Advanced Control System (ACS)
 - Selectable Joystick Controls (SJC)
 - Air ride seat with 2 point seat belt
 - Radio
 - Strobe
 - Back-up alarm
 - Beacon

1. Roll Over Protective Structure (ROPS) – meets requirements of SAE-J1040 and ISO 3471; Falling Object Protective Structure (FOPS) - meets requirements of SAE-J1043 and ISO 3449, Level I

- Dealer Installed Options
 - Cab enclosure kit
 - Special applications front door kit
 - 200 lbs (74.4 kg) counterweight kit
 - Front axle counterweight kit
 - Fuel cap locking kit
 - Deluxe instrument panel
 - Replacement Bob-Tach™
 - Fresh air heater kit
 - Front door kit
 - Door sensor kit
 - Plumbing kit for fresh air heater
 - Back up alarm kit
 - FOPS kit **
 - Single-point lift kit
 - Power Bob-Tach™ kit
 - Operator cab, CE, enclosure kit
 - 7-pin attachment control kit
 - Four-point lift kit
 - Rear auxiliary hydraulic kit
 - Engine block heater kit
 - Road kit
 - Bucket positioning kit
 - Keyless kit
 - Rear window wiper kit
 - 14-pin attachment control kit
 - 4-Way flasher kit
 - 80 mm Suspension seat kit
 - Cup holder kit
 - Headlight guard kit
 - Muffler guard kit
 - Tail light guard kit

Attachments

- Angle Brooms
- Augers
- Backhoes
- Bale Forks
- Breakers
- Brush Saws
- Bucket Adapters
- Concrete Mixers
- Construction / Industrial Buckets
- Cutter Crushers
- Diggers
- Dozer Blades
- Dumping Hoppers
- Fertilizer Buckets
- Flail Cutters
- General Purpose Buckets
- Graders
- Grapples, Industrial
- Pallet Forks, Standard
- Planers
- Root Grapples
- Scarifiers
- Scrapers
- Seeders
- Skeleton Buckets
- Snow & Light Material Buckets
- Snow Blades
- Snowblowers
- Snow Pushers
- Snow V-Blades
- Sod Layers
- Soil Conditioners
- Spare Wheels
- Spreaders
- Stabilizers
- Sweepers

- Landplanes
- Landscape Rakes
- Laser Equipment
- Low Profile Buckets
- Miscellaneous
- Mowers
- Packer Wheels
- Pallet Fork Accessories
- Pallet Forks, Hydraulic
- Tillers
- Tilt-Tatch
- Tracks
- Trenchers
- Utility Forks
- Utility Frames
- Vibratory Rollers
- Water Kits
- Whisker Brooms

Environmental

Operator LpA(98/37 & 474-1)	87 dB(A)
Noise level LWA(EU Directive 2000/14/EC)	101 dB(A)
Whole body vibration (ISO 2631-1) High speed	1.29 ms ⁻²
Whole body vibration uncertainty	0.52 ms ⁻²
Hand-arm vibration (ISO 5349-1) High speed	1.73 ms ⁻²

Safety

Bobcat Interlock Control System (BICS), standard

Requires the operator to be seated in the loader with the seat bar in place and the engine running. After the operator presses the “Press to Operate Loader” button, the loader’s hydraulic lift and tilt functions and traction drive can be operated.

Lift arm bypass control, standard

Used to lower the lift arms in the event that the lift arms cannot be lowered during normal operating conditions. Should always be worn when operating the loader.

Seat belt, standard

Three-point shoulder belt provides restraint for high range speeds.

Seat bar, standard

Secondary operator restraint, also serves as an arm rest.

Operator cab, standard

An enclosed operator cab with side screens with a minimal inside cab width of 838 mm. Meets SAE-J1040 and ISO 3471 for Roll Over Protective Structure (ROPS) and SAE-J1043 and ISO 3449 Level I * for Falling Objects Protective Structure (FOPS). Level II ** option is available.

Lift arm support, standard

* Level I — Acceptance is intended for protection from falling bricks, small concrete blocks, and hand tools encountered in operations such as highway maintenance, landscaping, and other construction site services.

Parking brake, standard

** Level II — Acceptance is intended for protection from falling trees or rocks for machines involved in site clearing, overhead demolition, or forestry.

Grab handles, standard

Use for servicing when lift arms are raised.

Safety tread, standard

Always set brake when leaving loader.

Attachment steps, standard

Should always be used when entering/exiting loader.

Rear window, standard

Slip resistant tread on lift arms and main frame to be used when entering/exiting loader.

Front and rear work lights, standard

Should always be used when entering/exiting loader.

Back-up alarm, optional

For emergency exit.

Lift kits, optional

Use for indoor and low light operation.

Special applications kit, optional

For use in areas with high traffic

Operator handbook, standard

Lift kits are available so loader may be lifted into remote areas.

Restricts objects and material from entering cab openings. Weather-resistant operator handbook attached to the inside of the cab, providing operational instructions and warnings decals with pictorials and international symbols.